

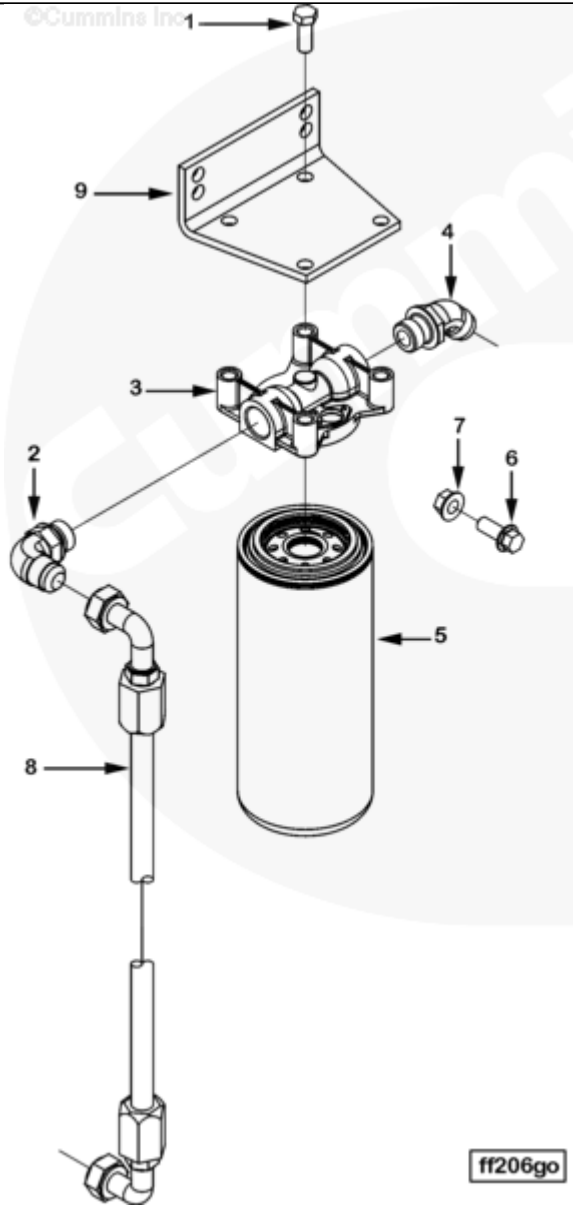

# Parts Catalog - Option Detail

Electronic Parts Catalog - Option Detail				
Option	Group	Graphic	Film Card	Date
FF2205-02	06.04	ff206go	II	08-MAY-06
<b>Engines</b>	ISM CM570, ISM CM570/870, ISM CM875, ISM CM876, ISM CM876 E, ISM11 CM876 M103, ISM11 CM876 SN, M11 CELECT, M11 CELECT PLUS, M11 MECHANICAL, QSM11 CM570, QSM11 CM876			



ff206go

SMALL | MEDIUM | LARGE

Cart	Ref No	Part Number	Part Description	Required	Remarks
<a href="#">View My Cart</a>					
		FF2205-02	Fuel Filter		

					Fuel Filter
					Water in Fuel Sensor
					Included: No
					Fuel Filter Supplier:
					Cummins
					Fuel Pump Type: Celect
					Fuel Filter Location: Remote
					Mounted
					Element Type: Single Spin-On
					Water Separator Provision:
					Yes
					Drain Provision: Yes
					Check Valve: No
					Pump Inlet Fitting: 90
					Degree Elbow
					Heater Element: No
					Decal: Fleetguard
					Remote Filter Plumbing: 32
					Inch Hose Kitted
					Air Compressor Provision: No
					Compressor Mounted on Engine
					Fuel Pump Inlet Fitting
					Orientation: 11:00 as Viewed
					from Rear of Engine
					Fuel Plumbing Routing:
					Pressure Side
					Filtration Measurement
					(Microns): 10
					Filter Model: FS1009

					Pump Inlet Diagnostic
					Provision: Yes
<input type="checkbox"/>	1	<a href="#">S 112</a>	Hexagon Head Cap Screw	4	3/8 - 16 X 1 in.
<input type="checkbox"/>	2	<a href="#">129859</a>	Male Union Elbow	1	
<input type="checkbox"/>	3	<a href="#">142784</a>	Fuel Filter Head	1	Purchase Cummins Filtration.
<input type="checkbox"/>	4	<a href="#">200293</a>	Male Union Elbow	1	
	5	<a href="#">3331673</a>	Fuel Water Separator	1	
<input type="checkbox"/>	6	<a href="#">3902460</a>	Hexagon Flange Head Cap Screw	2	M10 X 1.50 X 25.
<input type="checkbox"/>	7	<a href="#">3902662</a>	Hexagon Flange Nut	2	M10 x 1.50
<input type="checkbox"/>	8	<a href="#">4003438</a>	Flexible Hose	1	
<input type="checkbox"/>	9	<a href="#">4962719</a>	Filter Bracket	1	

© 2019 Cummins Inc., Box 3005, Columbus, IN 47202-3005 U.S.A.  
Terms of Use and Disclaimers | Recommended System Requirements  
Need Assistance? Please click on the Contact Us button in the top right corner of any page.